

OPERATION MANUAL

1. SUMMARIZE

The meter is a stable multimeter with 25mm LCD display, driven by battery. It's widely used on measuring DCV, ACV, DCA, ACA, resistance, capacitance, diode, transistor, and continuity test. It's an ideal tool for lab, factory and family.

2. SAFETY NOTE

The meter meets the standards of IEC1010. Read the operation manual carefully before operation.

2-1. Do not input limit over-ranged.

2-2. The voltage below 36V is safety. To avoid electric shock, check whether the test leads are connected correctly, whether the insulation is good when measuring over 36DCV or 25ACV.

2-3. Remove the test leads when changing function and range.

2-4. To select correct function and range, beware of error operation.:

2-5. Do not operate the meter if battery case and back cover is not fixed.

2-6. Do not input voltage when measuring resistance.

2-7. Remove test leads from test point and turn off the power before replacing battery and fuse.

2-8. SAFETY SYMBOLS

“” EXISTS DANGEROUS VOLTAGE, “” GND, “” DUAL INSULATION

“” THE OPERATOR MUST REFER TO THE MANUAL , “” LOW BATTERY

3. CHARACTERISTIC

3-1. GENERAL

3-1-1. Displaying: LCD displaying.

3-1-2. Max. displaying: 1999 (3 1/2 digit) auto polarity indication.

3-1-3. Measuring method: dual slope A/D conversion.

3-1-4. Sampling rate: approx. 3 times/second.

3-1-5. Overrange indication: the MSD displays “1” or “-1”.

3-1-6. Low battery indication: “” appears.

3-1-7. Operation environment: (0~40) °C, R.H.<80% .

3-1-8. Power: 9V×1 (NEDA1604/6F22 or equivalent model) .

3-1-9. Size: 175×93×55mm

3-1-10. Weight: approx. 400g (including battery) .

3-2. TECHNICAL CHARACTERISTIC

3-2-1. Accuracy: $\pm(a\% \times rdg + d)$ at (23±5)°C, R.H.<75%, one year guaranteed from the production date.

3-2-2. TECHNICAL DATA

3-2-2-1. DCV

RANGE	ACCURACY	RESOLUTION
200mV	±(0.5%+3)	100uV
2V		1mV
20V		10mV
200V		100mV
1000V	±(0.8%+10)	1V

Input resistance: 10MΩ for all ranges.

Overload protection: 250V DV or AC peak value at 200mV range.

1000V DC or AC peak value at other ranges.

3-2-2-2. ACV

RANGE	ACCURACY	RESOLUTION
2V	±(0.8%+5)	1mV
20V		10mV
200V		100mV
750V	±(1.2%+10)	1V

Input resistance: 10MΩ

Overload protection: 1000V DC or AC peak value

Frequency response: ≤200V range: (40~400) Hz , 750V range: (40~200) Hz

Display: sine wave RMS (mean value response)

3-2-2-3. DCA

RANGE	ACCURACY	RESOLUTION
20uA	±(0.8%+10)	10uA
2mA		1uA
200mA	±(1.2%+8)	100uA
20A	±(2.0%+5)	10mA

Max. input volt drop: 200mV

Max. input current: 20A (the test time should be in 10 seconds)

Overload protection: 0.2A/250V fast-blown fuse, 20A un-fused

3-2-2-4. ACA

RANGE	ACCURACY	RESOLUTION
2mA	±(1.0%+15)	1uA
200mA	±(2.0%+5)	100uA
20A	±(3.0%+10)	10mA

Max. measuring volt drop: 200mV

Max. input current: 20A (the test time should be in 10 seconds)

Overload protection: 0.2A/250V fast-blown fuse, 20A un-fused

Frequency response: (40~200)Hz

Display: sine wave RMS (mean value response)

3-2-2-5. RESISTANCE (Ω)

RANGE	ACCURACY	RESOLUTION
200Ω	±(0.8%+5)	0.1Ω
2kΩ		1Ω
20kΩ		10Ω
200kΩ		100Ω
2MΩ	±(1.0%+25)	1kΩ
20MΩ		10kΩ

Open voltage: less than 0.7V

Overload protection: 250V DC and AC peak value

NOTE: at 200Ω range, the test leads should be short-circuit, and measure the down-lead resistance, then, subtract from the real measuring.

WARNING: DO NOT input any voltage at resistance range for safety!

3-2-2-6. CAPACITANCE (C)

RANGE	ACCURACY	RESOLUTION
20nF	±(2.5%+20)	10pF
2uF		1nF
200uF	±(5.0%+10)	100nF

Overload protection: 36V DC or AC peak value

3-2-2-7. DIODE AND CONTINUITY TEST

Range	Displaying value	Test condition
	Positive voltage drop of diode	The positive DC current is approx. 1mA, negative voltage is approx. 3V
	Buzzer sounds, the resistance is less than (70±20)Ω	open voltage is approx. 3V

Overload protection: 250V DC or AC peak value

Warning: DO NOT input any voltage at this range for safety!

3-2-2-8. Triode hFE test

Range	Display range	Test condition
hFE NPN or PNP	0~1000	Basic current is approx. 10uA, Vce is approx. 3V

4. OPERATION

4-1 Front panel description

- Model
 - LCD display
 - Shine diode
 - .range knob
 - .20A current jack
 - “-” pole jack for capacitance, temp. and test accessory and less than 200mA current test jack.
 - “+” pole jack for capacitance, temp. test accessory and GND.
 - “+” pole jack for volt, resistance and diode.
 - Transistor test jack
- See the fig.

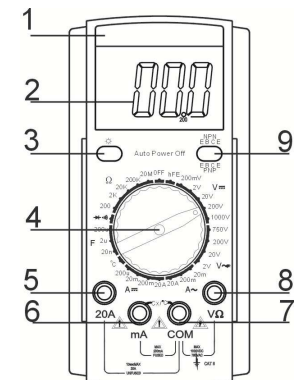

4-2. DCV MEASUREMENT

4-2-1. Insert the black test lead to “COM” jack, the red one to V/Ω jack.

4-2-2. Set the range knob to a proper DCV range, connect the test leads across to the circuit under tested, the polarity and voltage of the point which red lead connect will display on LCD.

NOTE:

1.If the measured voltage is unsure beforehand, should set the range knob to the highest range, then, switch to a proper range according to the displayed value.

2.If LCD displays “1”, it means overrange, should set the range knob to a higher range.

4-3.AC V MEASUREMENT

4-3-1.Insert the black test lead to “COM” jack, the red one to V/Ωjack.

4-3-2. Set the range knob to a proper ACV range, connect the test leads across to the circuit under tested.

NOTE:

1. If the measured voltage is unsure beforehand, should set the range knob to the highest range, then, switch to a proper range according to the displayed value.

2.If LCD displays “1”, it means overrange, should set the range knob to a higher range.

4-4.DCA MEASUREMENT

4-4-1.Insert the black test lead to “COM” jack and the red one to “mA” jack (max. 200mA), or insert the red one to “20A” jack (max. 20A) .

4-4-2.Set the range knob to a proper DCA range, connect the test leads across to the circuit under tested, the current value and polarity of the point which red lead connect will display on LCD.

NOTE:

1.If the measured current is unsure beforehand, should set the range knob to a higher range, then, switch to a proper range according to the displayed value.

2.If LCD displays “1” , it means overrange, should set the range knob to a higher range.

3.Max. input current is 200mA or 20A (subject to where red lead insert), excessive current will blow the fuse. Be careful when measuring 20A due to un-fused. Continuously measuring large current may heat the circuit, affect the accuracy, even damage the meter.

4-5. ACV MEASUREMENT

4-5-1. Insert the black test lead to “COM” jack and the red one to “mA” jack (max. 200mA), or insert the red one to “20A” jack (max. 20A) .

4-5-2.Set the range knob to a proper ACA range; connect the test leads across to the circuit under tested.

NOTE:

1.If the measured current range is unsure beforehand, should set the range knob to the highest range, then set to a proper range according to the displayed value.

2.If LCD displays “1” , it means overrange, should set the range knob to a higher range.

3.Max. input current is 200mA or 20A (subject to where the red lead insert to), excessive current will blow the fuse. Be careful when measuring 20A due to un-fused. Continuously measuring large current may heat the circuit, affect the accuracy, even damage the meter.

4-6. RESISTANCE MEASUREMENT

4-6-1. Insert the black test lead to “COM” jack and the red one to “V/Ω” jack.

4-6-2.Set the range knob to a proper resistance range, connect the test leads across to the resistance under measured.

NOTE:

1. If the resistance value being measured exceeds the max value of the range selected, LCD displays "1", thus, should set the range knob to a higher range. When the resistance is over 1MΩ,

the meter may take a few seconds to stabilize. This is normal for high resistance readings.

2.When input terminal is in open circuit, overload displays.

3.When measuring in-line resistance, be sure that power is off and all capacitors are released completely.◦

4-7. CAPACITANCE MEASUREMENT

4-7-1.Insert the red test lead to “COM” terminal and the black one to “mACx” jack.

4-7-2.Set the range knob to a proper capacitance range, connect the test leads to the capacitor under measured (note: the polarity of red test lead is “+”) .

NOTE:

1.If the capacitance range under measured is unsure beforehand, should set the range knob to the highest range, then, set to a proper range according to the displayed value.

2.If LCD displays “1” , it means overrange, should set the range knob to a higher range.

3.Before measuring, LCD display might not be zero, the residual reading will be decreased gradually and could be disregarded.

4.When measuring large capacitance, if creeps seriously or break capacitance, LCD will display some instability value.

5.Discharge all capacitors completely before capacitance measurement to avoid damage.

6.UNIT: 1uF =1000nF 1nF=1000pF

4-8.DIODE AND CONTINUITY TEST

4-8-1.Insert the black test lead to “COM” terminal and the red one to V/Ω jack(Note: the polarity of red test lead is “+”).

4-8-2.Set the range knob to “” range, connect the test leads to the diode under measured, reading is the approximation of the diode positive volt drop.

4-8-3.Connect the test leads to two points of the measured circuit, if buzzer sounds, the resistance is lower than approx.(70±20)Ω.

4-9.TRIODE hFE

4-9-1.Set the range knob to hFE.

4-9-2.Insert the positive pole to “COM” terminal and the negative pole to “mA” jack.

4-9-3.Verify the type of the transistor is NPN or PNP, insert the emitter, basic and collector to the proper jack on test accessory.

4-10. AUTO POWER-OFF

After stop operating for about(20±10) minutes, the meter is auto power-off to be in sleepy mode. Press POWER key twice to restart the power.

5.MAINTENANCE

DO NOT try to verify the circuit for it's a precision meter.

5-1.Beware of waterproof, dustproof and shockproof.

5-2.Do not operate and store the meter in the circumstance of high temperature, high humidity, and flammability, explosive and strong magnetic field.

5-3.Use the damp cloth and soft solvent to clean the meter, do not use abrasive and alcohol.

5-4.If do not operate it for a long time, should take out the battery.

5-4-1.When LCD displays “” symbol, should replace the battery as below:

5-4-1-1.Take out the holster and drop out the battery case.

5-4-1-2.ake out the battery and replace a new one. It's better to use alkalescency battery for long time use.

5-4-1-3.Fix the battery case and take on the holster.

5-4-2.Fuse replacement

To use the specified type when replacement.

6. If the meter does not work properly, check the meter as following:

CONDITIONS	WAY TO SOLVE
NO DISPLAYING	●Power is off ●HOLD key ●Replace battery
 symbol displays	●Replace battery
NO CURRENT INPUT	●Replace fuse
BIG ERROR	●Replace battery